

THIS DRAWING IS UNPUBLISHED. RELEASED FOR PUBLICATION
 BY AMP INCORPORATED. ALL RIGHTS RESERVED.

REVOLUTION		REVISIONS					
LOC	DIST	P	LTR	DESCRIPTION	DATE	DWN	APVD
BD	48						
		D		REV PER ECN BD6838	10/27/92	-	CA
		E		REV PER EC 0020-625-95	06/20/95	DH	CS
		F		OBS -6 PER EC 0420-145-96	16 SEP 97	MB	SB

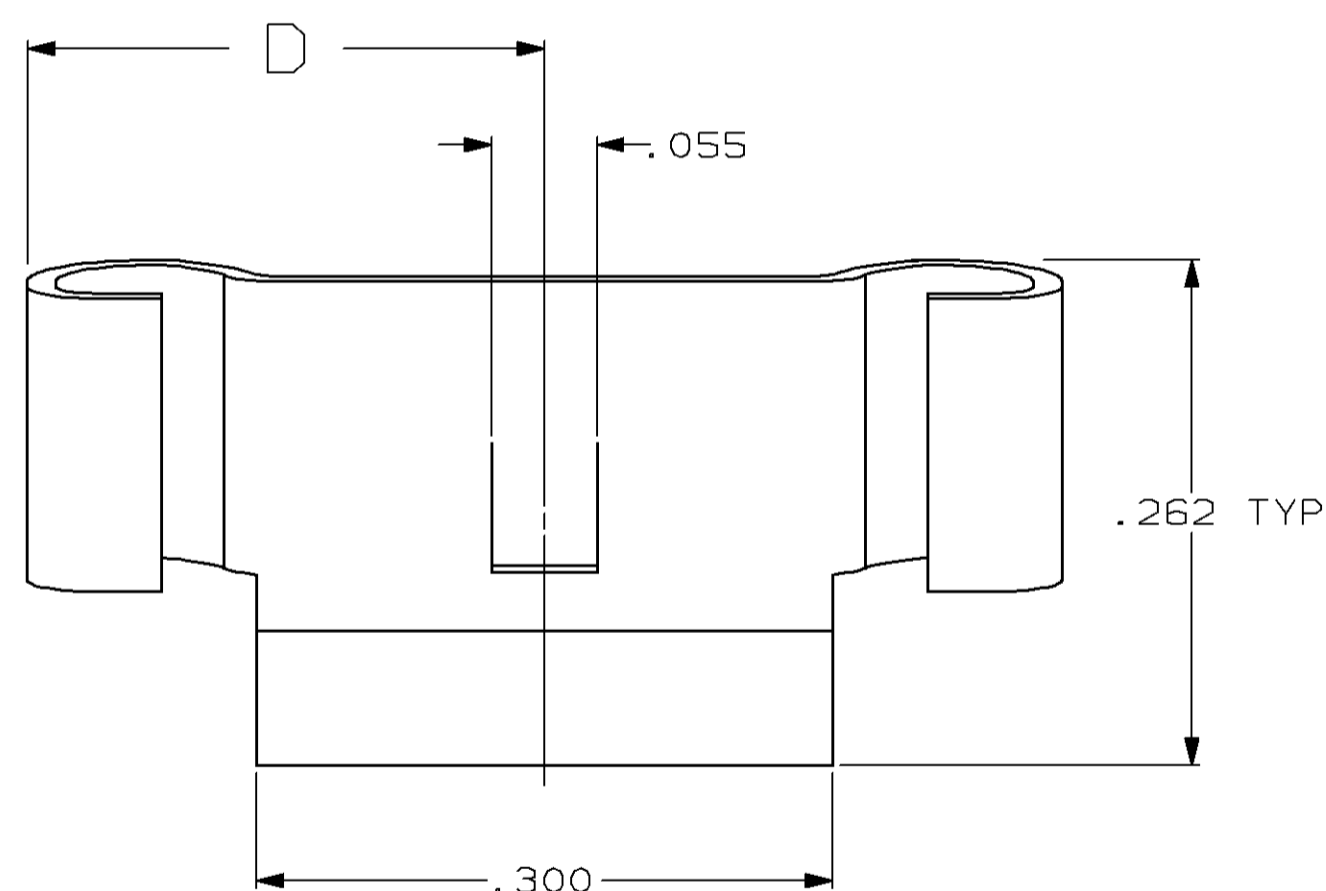
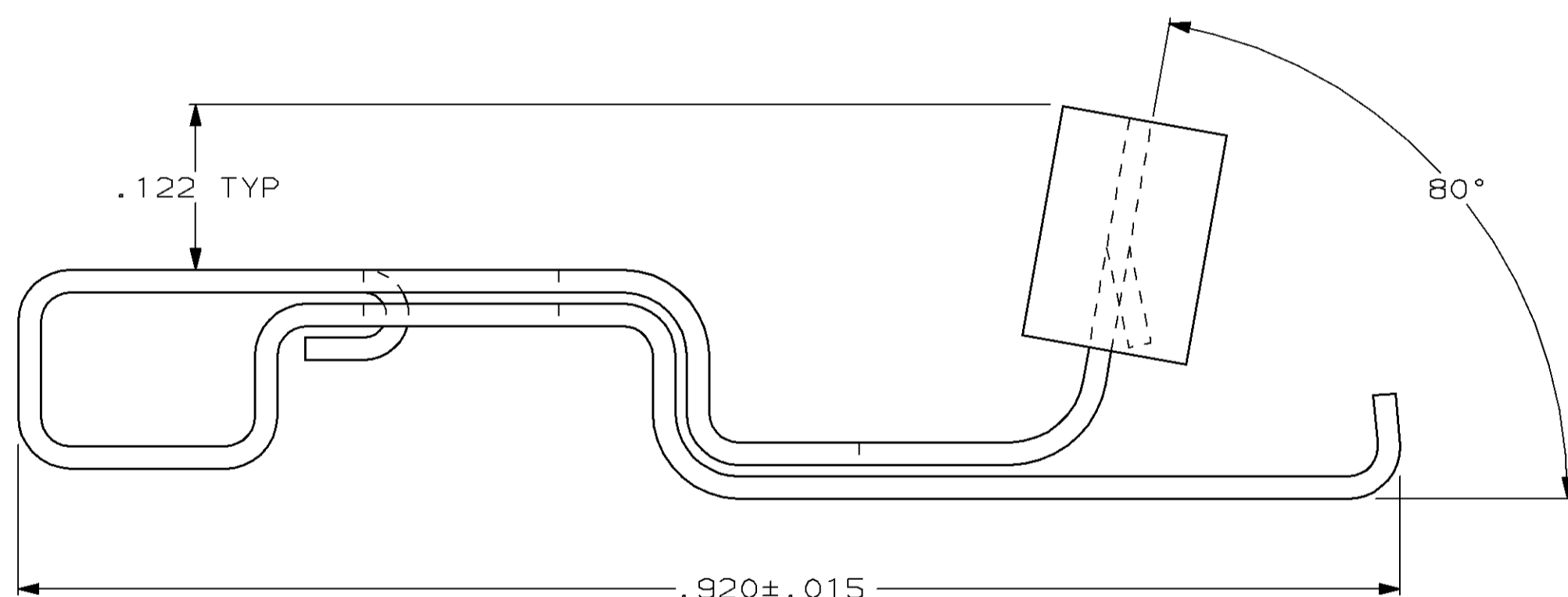
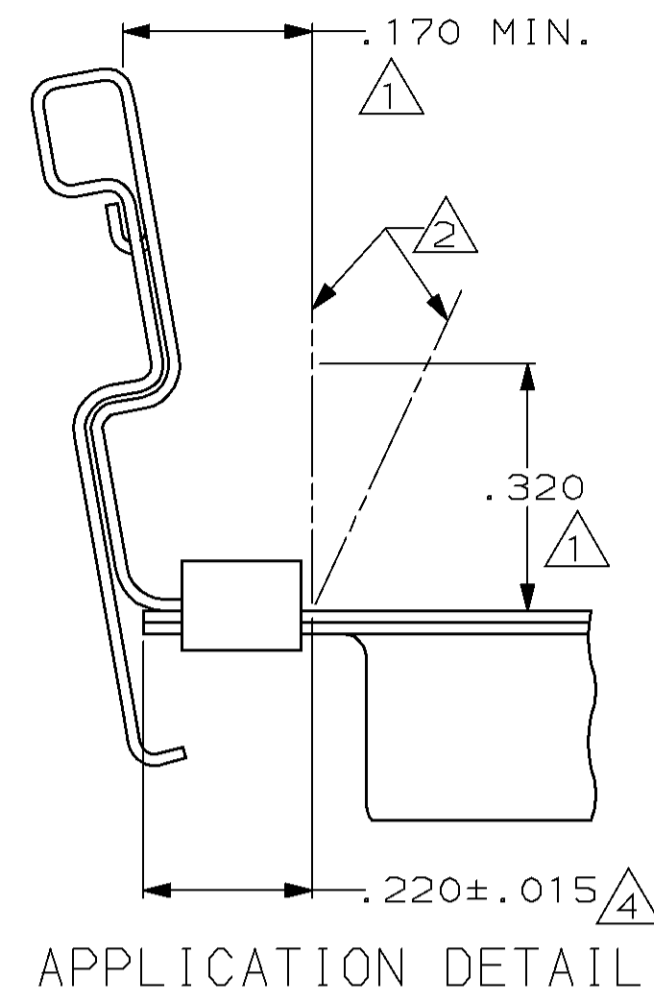
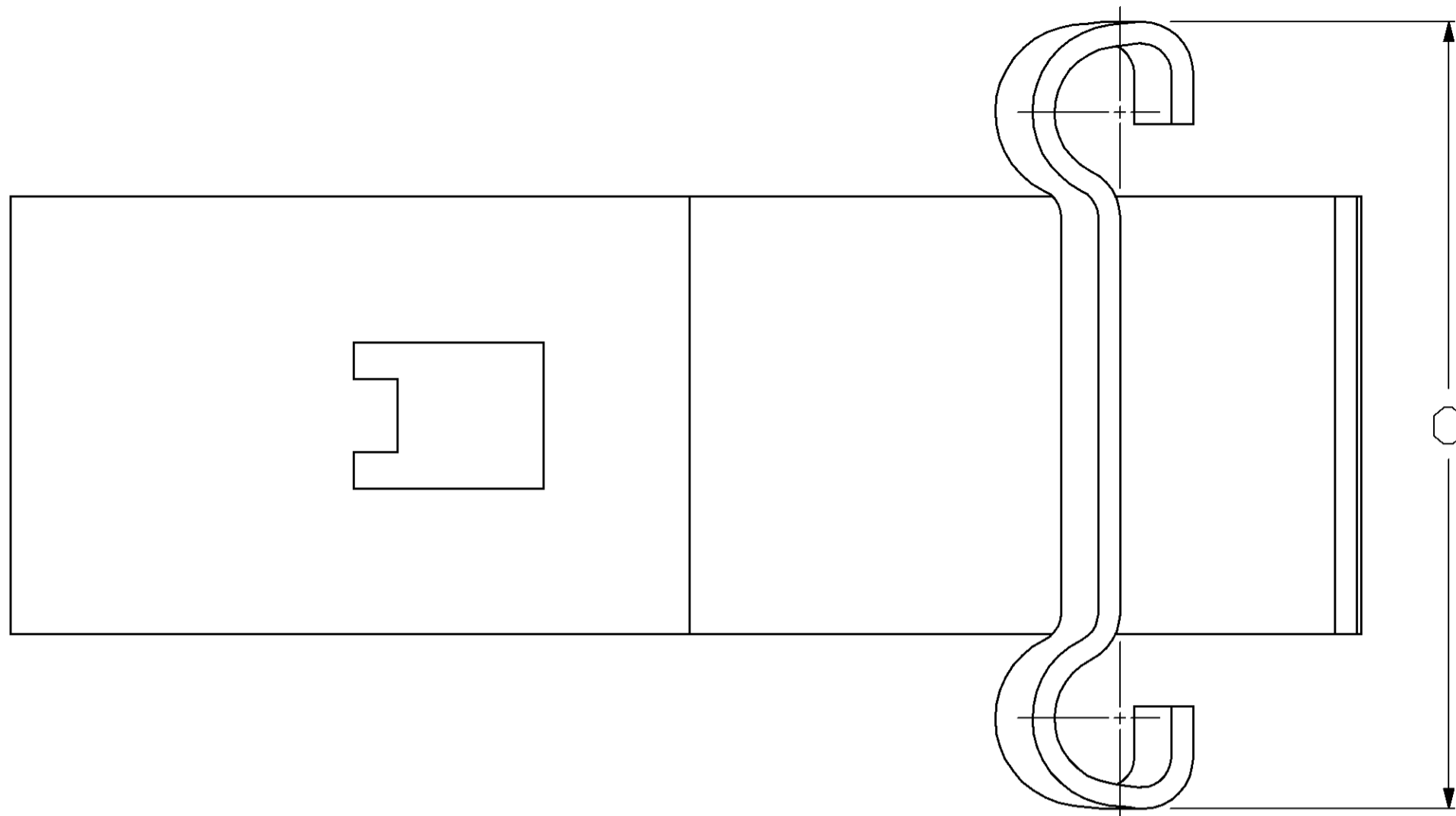

- ⚠ FOR SATISFACTORY OPERATION THESE DIMENSIONS MUST BE MAINTAINED, .170 DIMENSION SHOULD BE MEASURED AT HEIGHT OF .320 MIN.
- ⚠ SPRING LATCH ACCOUNTS FOR DESIGN VARIATIONS IN THE ENVELOPE OF POST MOLDED STRAIN RELIEFS.
- ⚠ WHEN ORDERING SPRING LATCHES SPECIFY NUMBER OF CONNECTORS, QUANTITY SHIPPED WILL BE BASED ON 2 SPRING LATCHES REQUIRED PER CONNECTOR.
- ⚠ MEASURED FROM END OF CONNECTOR FLANGE TO END OF TAB ON SPRING LATCH.

OBSOLETE	.325	.650	BULK	3	745779-6
	.325	.650	2 PIECE UNIT		745779-5
	.270	.540	BULK	3	745779-3
	.270	.540	2 PIECE UNIT		745779-2
	D	C	KIT PACKAGING		PART NO

THIS DRAWING IS A CONTROLLED DOCUMENT FOR AMP INCORPORATED. IT IS SUBJECT TO CHANGE AND THE CONTROLLING ENGINEERING ORGANIZATION SHOULD BE CONTACTED FOR THE LATEST REVISION.		DWN J. GERACE 02-24-83	AMP Incorporated Harrisburg, PA 17105-3608
DIMENSIONS: INCHES		CHK J. GERACE 02-24-83	
TOLERANCES UNLESS OTHERWISE SPECIFIED:		APVD R. LEGGETT 02-24-83	NAME SPRING LATCH, 2 PIECE, AMPLIMITE™
0 PLC ± 1 PLC ± 2 PLC ± 3 PLC ±.010 4 PLC ±		PRODUCT SPEC -	
MATERIAL: STAINLESS STEEL		FINISH -	SIZE A2
		ANGLES ±3°	CAGE CODE 00779
			DRAWING NO C=745779
			SCALE 10:1
			SHEET 1 OF 1
			REV F
			CUSTOMER DRAWING

745779